

# Terminator™ DL

Lighted Power Connection/End Termination Kit

## INSTALLATION PROCEDURES

For Power Connection or End Termination Applications



**The Heat Tracing Specialists®**

# Terminator DL

The following installation procedures are suggested guidelines for the installation of termination connection systems. They are not intended to preclude the use of other methods and good engineering or field construction practices.

## Receiving, Storing and Handling . . .

1. Inspect materials for damage incurred during shipping.
2. Report damages to the carrier for settlement.
3. Identify parts against the packing list to ensure the proper type and quantity has been received.

## Kit Contents . . .

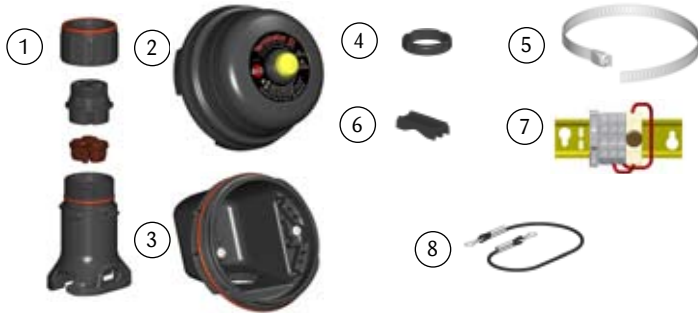

Item	Quantity	Description
1	1	Expediter Assembly Support Cap with O-Ring Threaded Grommet Compressor Grommet Support Base with O-Ring
2	1	Junction Box Lid with Lens
3	1	Junction Box Base with O-Ring
4	1	Nut
5	1	Banding
6	1	Banding Guide
7	1	Lamp Terminal Blocks with DIN Rail (22-8 AWG, 600 Vac, 50 Amp)
8	1	Junction Box Cord

## Certifications/Approvals . . .

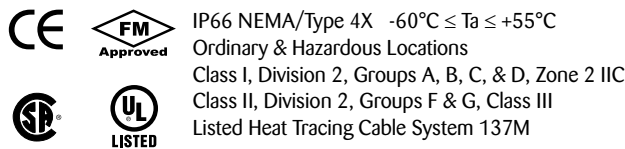

## Tools Required . . .



## Dimensions . . .

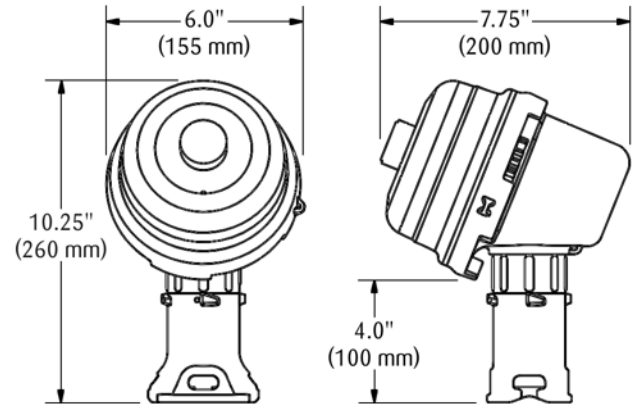

## Installation Precautions . . .

- To minimize the potential for arcing and fire caused by product damage or improper installation use ground-fault protection. The National Electrical Code (NEC) and Canadian Electrical Code (CEC) require ground-fault protection of equipment for each branch circuit supplying electric heat tracing.
- Installation must comply with Thermon requirements and be installed in accordance with the NEC, CEC, or any other applicable national and local codes.
- Component approvals and performance ratings are based on the use of Thermon specified parts only. User supplied power connection fittings must be listed or certified for intended use.
- De-energize all power sources before opening enclosure.
- Keep ends of heating cable and kit components dry before and during installation.

## Order Separately . . .

### PETK Power and End Termination Kits (per cable)

PETK-1 D for BSX, RSX, TSX, VSX

PETK-2 D for KSX, HTSX

PETK-3 D for HPT, FP



Item	Quantity	Description
1	1	RTV Tube
2	1	Power Connection Boot
3	1	End Cap
4	1	Tape Strip Teflon 6" (PETK-3 only)
5	1	End Termination Caution Label
6	1	GRW-G Grommet (PETK-3 only)

# Terminator DL

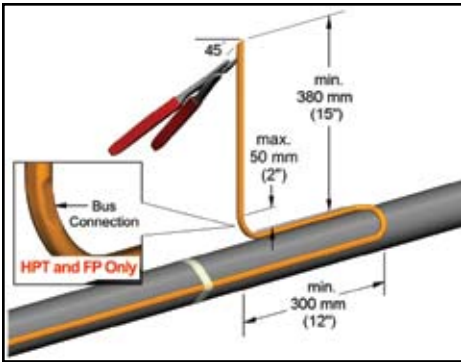

1. Locate bus connection (HPT and FP only) and cable as shown. Cut end of cable at angle to aid in piercing grommet. Leave additional cable for expansion loop.

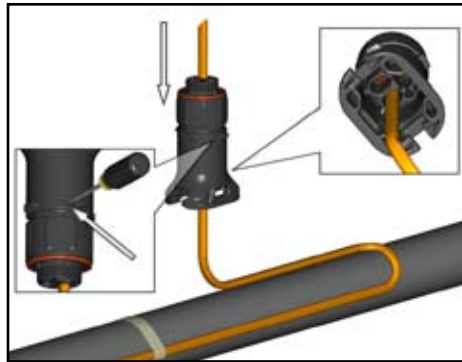

2. Insert cable into expediter. If mounted on bottom of pipe, punch out weep hole.

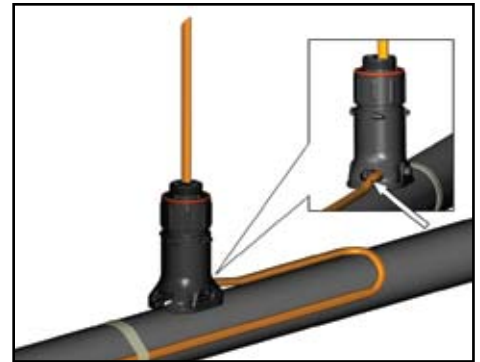

3. Slide expediter toward pipe and route cable through support base entry.



4. Insert banding guide into expediter and snap into place.



5. Mount expediter to pipe using pipe band. Do not band over cable.

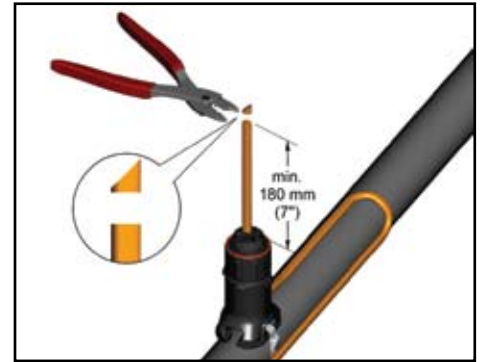

6. Cut off end of cable.



7. Terminate cable with appropriate PETK termination kit. Refer to PETK installation instructions.

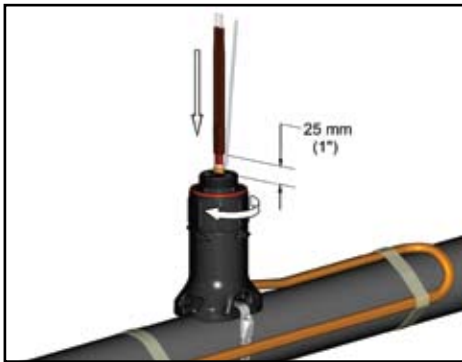

8. Push excess cable back through expediter. Tighten cap securely. Tape cable expansion loop to pipe.



9. For power connection applications: Use dimple molded into side of junction box base to locate center of hole, drill for user supplied power connection fittings per manufacturer's recommendations.



# INSTALLATION PROCEDURES



**10.** Mount junction box base on expediter. Make sure to align slots to properly orient junction box base. Tighten nut securely.



**11.** For power connection applications: Install power connection fittings (user supplied) and pull in power and ground wires.

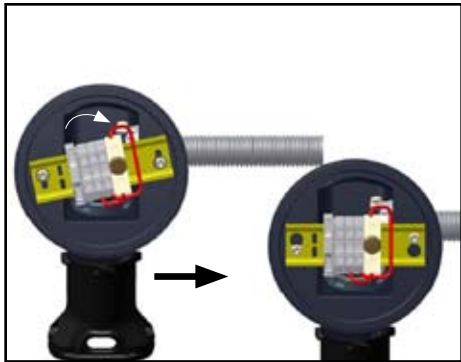

**12.** Install quick mount terminal blocks.



**13.** Complete system wiring. Refer to typical wiring details.

## Typical Wiring Details

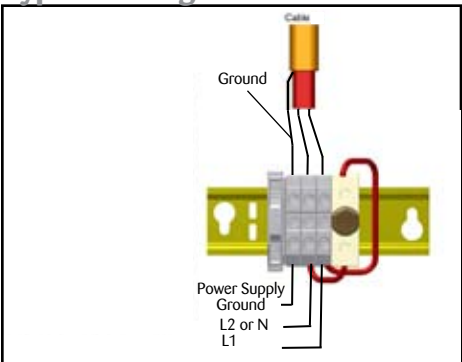

Power Connection (1 Cable). When using 10 mm<sup>2</sup> (#8 AWG) power supply wiring, additional terminal blocks will be required.

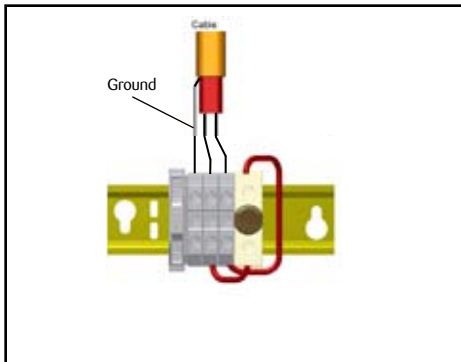

End Termination (1 Cable Only)

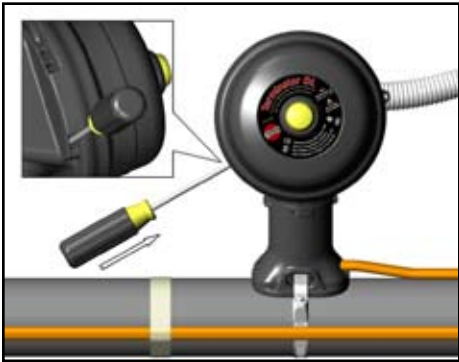

**14.** Install junction box lid and twist hand tight. Insert screwdriver into ratchet slots located on side of junction box base.

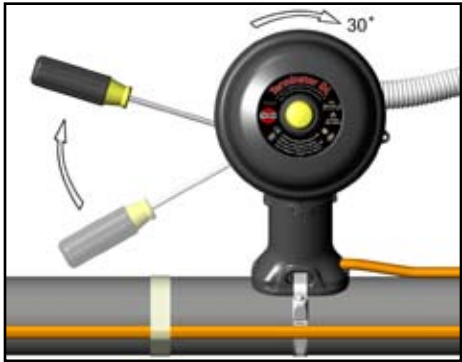

**15.** Use screwdriver to ratchet on junction box lid. Lid will rotate 30 degrees.

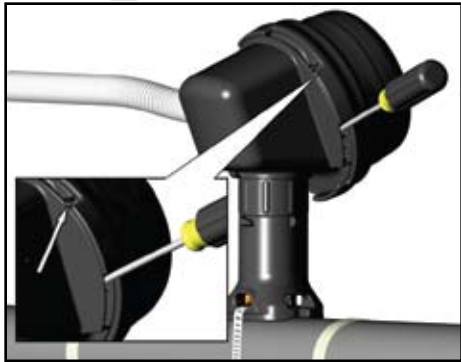

**16.** Lid latch mechanism fully engaged. To remove lid, repeat steps 14 and 15 but in the opposite direction.



The Heat Tracing Specialists®



**ISO 9001**  
REGISTERED

**THERMON . . . The Heat Tracing Specialists®**

100 Thermon Dr. • PO Box 609 • San Marcos, TX 78667-0609  
Phone: 512-396-5801 • Facsimile: 512-396-3627 • **1-800-820-HEAT**  
www.thermon.com In Canada call **1-800-563-8461**

Specifications and information are subject to change without notice.