

### Main applications

- Climatic chambers and test benches
- Furnaces and ovens that require a setpoint that varies with time
- Steriliser, autoclaves, dryers, plant for transformation
- Chemical and pharmaceutical industries
- Food processing plants
- Water treatment
- Siderurgy industry
- Furnaces for ceramics and bricks
- Heat exchange control



### Main features

- Cascade control
- Ratio control
- Square root extraction on input signal
- Programmer with 4 setpoints and 4 ramps
- Thermocouple or resistance thermometer inputs and linear inputs with configurable scale and linearisation
- Isolated inputs for remote setpoint, valve position feedback signal or load break detection
- Two control outputs with independent PID parameters (Heat/Cool)
- AUTO/MAN station with bumpless transfer incorporated
- Configurable output for a retransmission signal
- Serial line: optoisolated 4-wires configurable.  
Protocol: GEFran CENCAL

### GENERAL

Microprocessor controller in 48x96 / 96x96mm format (1/8 DIN - 1/4 DIN). Manufactured using SMT, the 3400 provides a complete operator interface with IP54 level of protection (IP65 with faceplate cover).

The faceplate has a membrane keypad with 6 keys, a backlit LCD display that is available also with large dimensions (model 4400) that displays the process variable, setpoint, bargraphs of the percentage output power and the deviation and indication of the alarm and controller states.

The main input for the control variable is universal and gives the possibility to connect a wide range of sensors such as thermocouples, resistance thermometers or mV signals even with custom linearisation.

A second auxiliary analogue input is available for remote setpoint linear signal, potentiometer valve position feedback or input from a current transformer.

With a digital input it is possible to select between two preset setpoints or switch between local and remote setpoint.

With three isolated digital inputs, it is possible to select one of four setpoint programmes or supply a start, stop and reset signal, or select local/remote, auto/manual or hold.

The instrument has up to four outputs, each one factory configured, according to the order code, as relay, isolated logic, isolated analogue or interface for MD81 expansion unit output.

The output functions are configurable from the faceplate.

Apart from the control outputs, that can be heat-cool with independent PID, and the alarm outputs, outputs can be dedicated to the open/close control of a motorised valve (with or without position feedback potentiometer), retransmission signal of the measured variable, the setpoint, the deviation or the control of the MD8 expansion unit for an extra 8 alarms.

The 3400/4400 series controllers can be used as setpoint programmers with up to 8 segments (4 ramps and 4 holds).

Other control functions are also available such as ratio control between two variables and cascade control with specific and configurable parameters.

The serial communication option can be for Current Loop, RS232 or RS485 and it is possible to read and write any of the instrument's parameters.

The programming procedure is simplified by the menu guide structure with different configuration levels for a rapid and easy access to the data.

### TECHNICAL DATA

#### INPUTS

Accuracy 0,1% f.s.  $\pm 1$  digit  
Sampling time 120msec

#### TC- Thermocouple

**J** (Fe-CuNi) 0...1000°C / 32...1832°F  
**K** (NiCr-Ni) 0...1300°C / 32...2372°F  
**R** (Pt13Rh-Pt) 0...1750°C / 32...3182°F  
**S** (Pt10Rh-Pt) 0...1750°C / 32...3182°F  
**T** (Cu-CuNi) -100...400°C / -148...752°F  
**B** (Pt30Rh-Pt6Rh) (\*) 50...1800°C / 122...3272°F  
**E** (NiCr-CuNi) -100...750°C / -148...1382°F  
**N** (NiCr-Si-NiSi) 0...1300°C / 32...2372°F  
**Ni-Ni18Mo** (Ni-Ni18Mo)  
 0...1100°C / 32...2012°F

(\*) for type B thermocouples, the class of accuracy is valid for temperatures above 500°C.

#### RTD 2/3-wires

Pt100 -200...600°C / -328...1112°F

#### DC - Linear

0...50mV, 10...50mV  
 External shunts are used for voltage ranges 0...10V and current ranges of 0...20mA and 4...20mA.  
 Custom 32 segment characterisation.  
 $R_i > 1M\Omega$ .

### Auxiliary input

Isolated 1500V

For remote setpoint:

0...10V - Ri > 100KΩ

0...20mA - Ri = 50Ω

4...20mA - Ri = 50Ω

For potentiometer:

0...1V - Ri > 10MΩ (potentiometer with value from 100Ω to 20KΩ)

For current transformer:

0...5Aac, 50/60Hz - Ri = 20mΩ

### Digital

Isolated 1500V

3 isolated command inputs for

Start/Stop/Reset functions, Set

Locale/Remoto, Auto/Man, Hold, direct

selection of one of the four program set-

points:

- NPN 12V/3,5mA

- PNP 24V/6mA (12V/2mA)

### OUTPUTS

Isolated 1500V

Maximum and minimum adjustment from the faceplate keys:

- Direct control (Heat)
- Inverse control (Cool)
- Retransmission of local or remote setpoint
- Retransmission of the input signal
- Retransmission of the deviation signal between the values of the setpoint and the input.
- Alarm 1 or 2
- Open/Close for valve positioner motor

### Continuous

0...10V max 20mA

0...20, 4...20mA Rmax = 500Ω

Resolution 4000 steps, max. update time 80msec.

### Relay

Contact, which can be selected as

NO/NC rated at 5A/250Vac at  $\cos\varphi = 1$

(with resistive load) with spark suppression on the NO contact.

### Logic

23Vdc, Rout = 470Ω (20mA, max.12V).

Voltage output for SSRs.

### MD81

MD81 expansion unit of the alarms (alarms 3...10)

### SERIAL LINE

The instrument is equipped with Passive Current Loop (1200 baud) interface or RS422/485, RS232 (1200 / 2400 / 4800 / 9600 baud).

Protocol: GEFTRAN CENCAL

### POWER SUPPLY

100...240Vac/dc  $\pm 10\%$ , 50/60Hz

12VA max (3400), 15VA max. (4400)

Protection by internal fuse not serviceable by the user.

### AMBIENT CONDITIONS

Working temperature: 0...50°C

Storage temperature: -20...70°C

Humidity: 20...85%Ur non condensing

### CONTROLLER

On/Off, P, PD, PI, PID control with independent and adjustable parameters for both the direct and the inverse actions.

By selecting a configuration parameter, the controller may be configured as:

- single loop, ratio and cascade controller.
- Cool setpoint relative to the heat setpoint  $\pm 25,0\%$  f.s.
- Two control outputs (Heat/Cool) with the Cool setpoint entered in the range:  $\pm 25,0\%$  f.s. with respect to the Heat setpoint
- Proportional band for direct action (Heat) 0,0...999,9% f.s.
- Proportional band for direct action (Cool) 0,0...999,9% f.s.
- Manual reset (deviation correction factor)  $\pm 999$  scale digits
- Offset of the primary input  $\pm 999$  scale digits

• Offset of the secondary input  $\pm 999$  scale digits

• Digital filter on the input variable:

0,1...20,0 sec

Mathematical operations on input signal:

square root extraction:

(A x Input <sup>D</sup> + B)/C

Scale configurable in the range:

-1999...9999.

• Reset power for direct / inverse action

(0...100% / 0...-100%)

• Antireset (limitation band for the integral action) 0...9999 scale digits

• Feed Forward 500...-199%

• Integral time for direct / inverse action

0,00...99,99 min

• Derivative time for direct / inverse action

0,00...9,99 min

• Maximum/minimum limit of the

direct/inverse action output 0...100%

The main control and support functions are:

• Soft-start: gradual increase of the main output after power-up of the instrument over a time 0,0...100,0 min

• Self-Tuning: automatic research for the optimal control parameters during the start-up phase.

• Auto-Tuning: automatic update of the tuning parameters following a variation of the controlled system and/or of the setpoint.

• AUTO/MAN station with bumpless transfer incorporated

• LBA: Loop Break Alarm with adjustable delay (0,0...20,0 min) and power (0,0...100,0%) of intervention

• HB: Heater Break or alarm for interrupted load with reference to the current transformer input.

### PROGRAMMER

The programmer function enables the

controlled variable to follow a profile of 8 segments (4 setpoints and 4 ramps).

Each step is defined by the following data:

## FACEPLATE DESCRIPTION

**A** - Indication of process variable, digits h. 10mm (3400) and 20mm (4400)

**B** - Indication of setpoint, digits h. 7mm (3400) and 14mm (4400)

**C** - Deviation display

**D** - Main output display

**E** - Function key

**F - G** - Lower/Raise keys

**H** - Data key

**I** - Man/Auto key

**L** - Local/Remote key

**M** - Status indicator

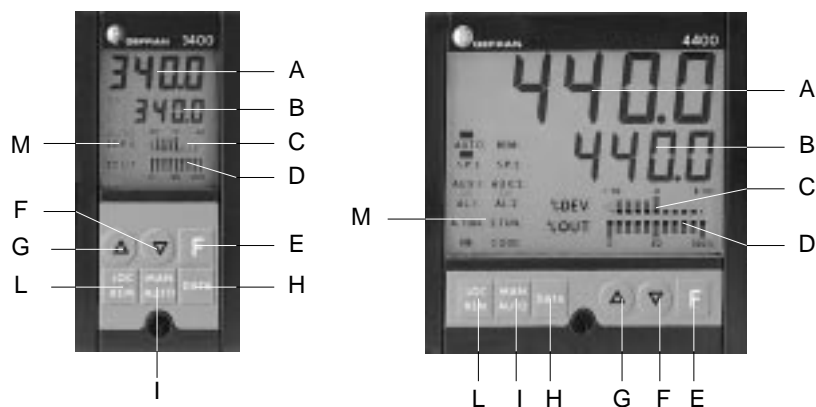

LCD backlit display

IP54 faceplate protection (IP65 available)

- Setpoint
  - Time of setpoint and of programmable ramp up to 99days 23hrs 59min. 59sec.
  - Accuracy of the time base: better than  $\pm 4$  sec every 10 hours.
  - H: Holdback band or maximum allowed deviation for the running of the program: 1...1000 scale digits.
- Program START/STOP/RESET commands:
- from the faceplate keys,
  - from the logic inputs,
  - from serial line
- In the STOP condition, it is possible to:
- vary the value of the current setpoint using the Raise and Lower keys.

- display and modify the set of the program being run.

**ALARMS**

- 2 + 8 (with the MD81 expansion unit) alarm levels that may be set as an absolute, relative or symmetrically relative value with respect to the setpoint or auxiliary input; with direct or inverse action and possibility to inhibit the alarm during power-up.
- The faceplate keys are used to configure the alarms in condition of LBA, HB, H and end-of program alarms.
- Programmable limits for the entered parameters may be configured within the

selected scale.

- Programmable hysteresis for each alarm  $\pm 999$  scale digits.
- Non-repetitive response time: max. 80msec.
- Indication: the messages AL1 and AL2 appear or the LEDs of the MD81 alarm unit light up in phase of entering the relative setpoints, and flash when the output relay is energised or the output is active.

**WEIGHT**

- 600g (3400)
- 850g (4400)

**DIMENSIONS AND CUT-OUT**

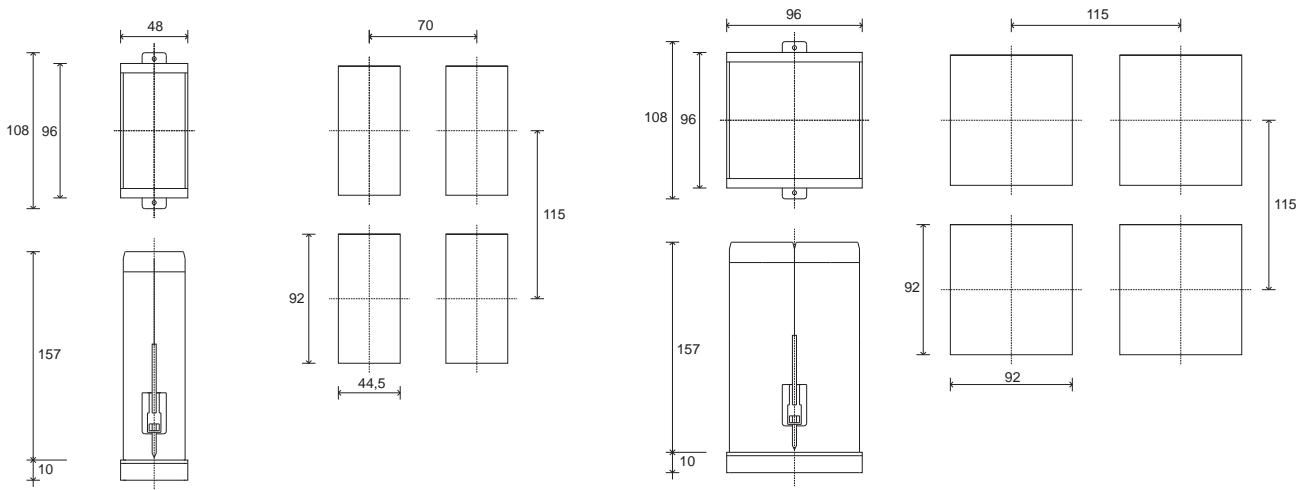

Dimensions: 48x96mm - 96x96mm (1/8 DIN - 1/4 DIN), depth 157mm

**CONNECTION DIAGRAM**

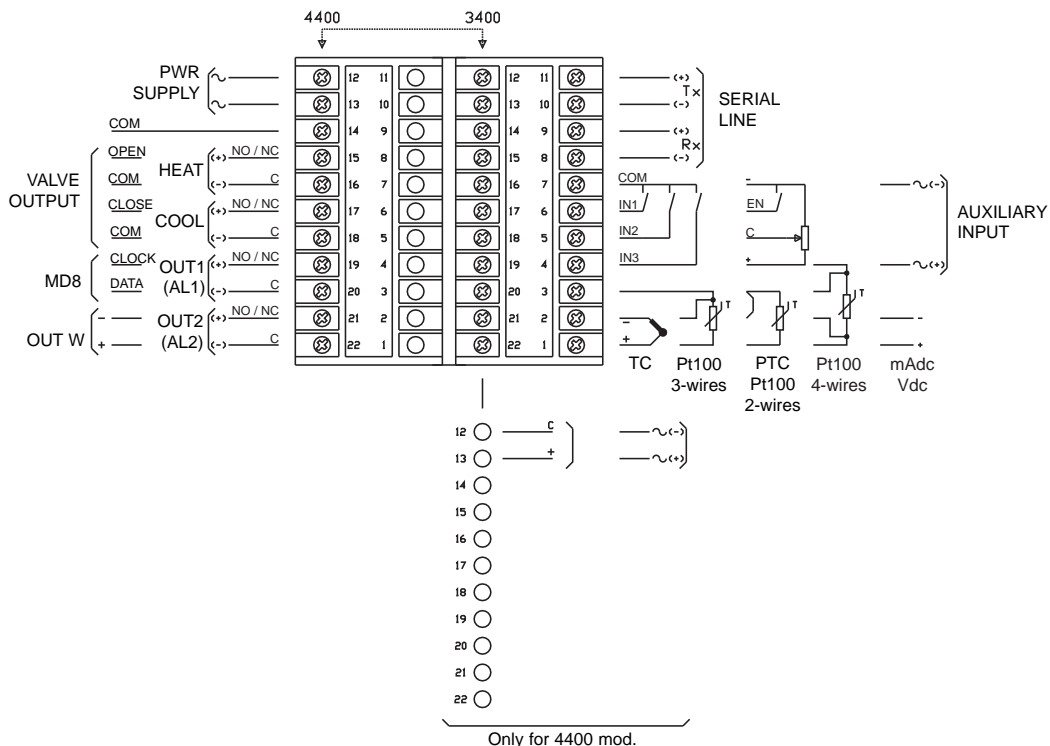

Only for 4400 mod.

Apply users' manual warnings for a correct installation

# ORDER CODE

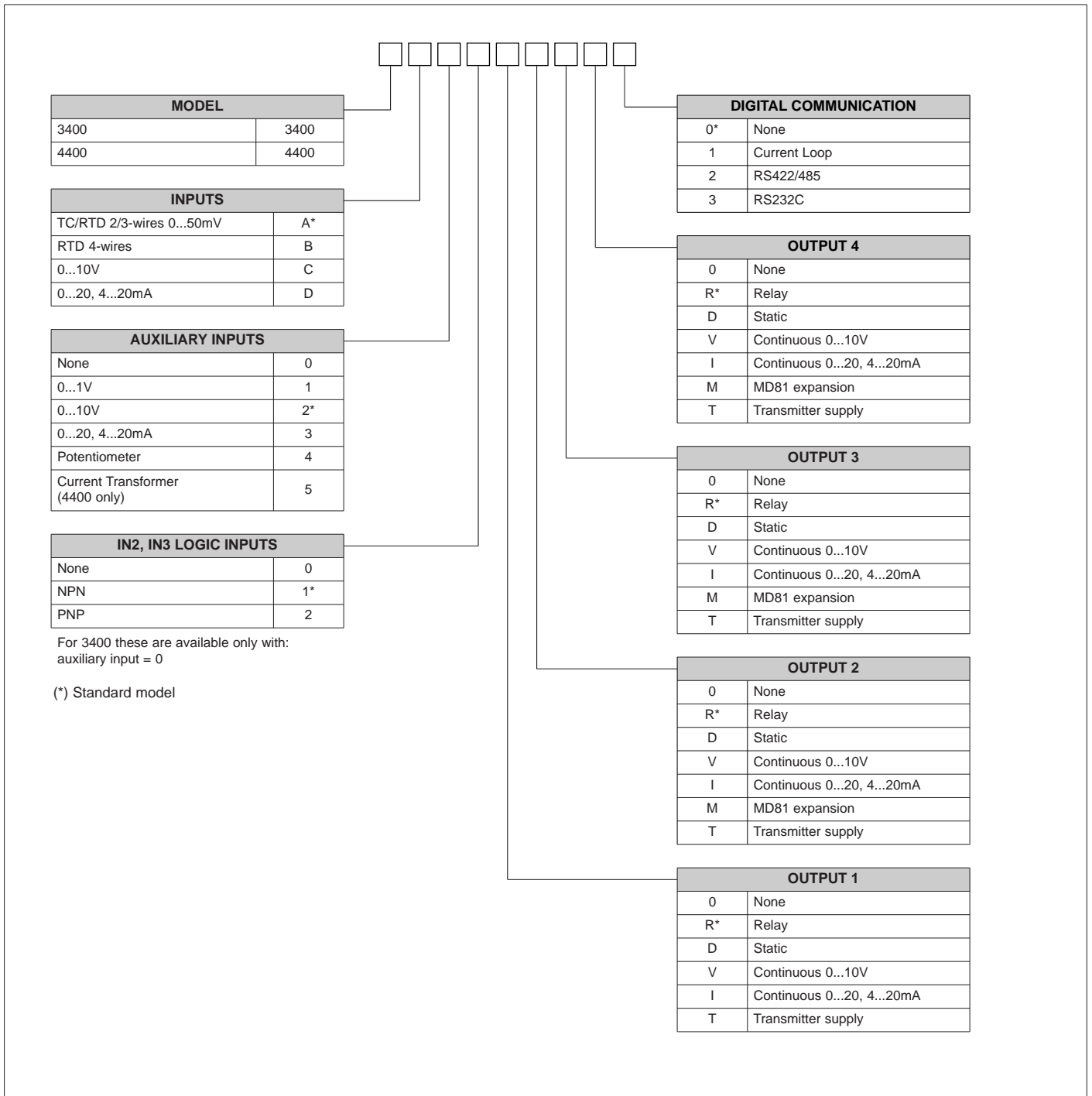

MODEL	
3400	3400
4400	4400

INPUTS	
TC/RTD 2/3-wires 0...50mV	A*
RTD 4-wires	B
0...10V	C
0...20, 4...20mA	D

AUXILIARY INPUTS	
None	0
0...1V	1
0...10V	2*
0...20, 4...20mA	3
Potentiometer	4
Current Transformer (4400 only)	5

IN2, IN3 LOGIC INPUTS	
None	0
NPN	1*
PNP	2

DIGITAL COMMUNICATION	
0*	None
1	Current Loop
2	RS422/485
3	RS232C

OUTPUT 4	
0	None
R*	Relay
D	Static
V	Continuous 0...10V
I	Continuous 0...20, 4...20mA
M	MD81 expansion
T	Transmitter supply

OUTPUT 3	
0	None
R*	Relay
D	Static
V	Continuous 0...10V
I	Continuous 0...20, 4...20mA
M	MD81 expansion
T	Transmitter supply

OUTPUT 2	
0	None
R*	Relay
D	Static
V	Continuous 0...10V
I	Continuous 0...20, 4...20mA
M	MD81 expansion
T	Transmitter supply

OUTPUT 1	
0	None
R*	Relay
D	Static
V	Continuous 0...10V
I	Continuous 0...20, 4...20mA
T	Transmitter supply

GEFRAN spa reserves the right to make any kind of design or functional modification at any moment without prior notice

**CE** In conformity to ECC 89/336/CEE and 73/23/CEE with reference to standards:  
- EN 50082-2 (immunity in industrial environment) - EN 50081-1 (emission in residential environment) - EN 61010-1 (safety)



GEFRAN spa via Sebina, 74 - 25050 Provaglio d'Iseo (BS)  
Tel. 03098881 - fax 0309839063 - Internet: <http://www.gefran.com>



cod. 80162 - 07/00